

QC Simple™

MP EQUIPMENT IS PROUD TO INTRODUCE TO ITS PRODUCT LINE THE LATEST INNOVATION IN PLANT LEVEL QUALITY CONTROL, MANUFACTURED BY



MP Equipment and PES have again teamed together to bring to market the latest in Quality Control data acquisition. QC Simple™ quickly and accurately captures all product attributes, eliminating costly manual measurements. Using cutting-edge technologies in scanning, weighing and temperature probing, all measurements are gathered in a single pass.

Machine Features

- Automated weighing, dimensional and temperature measurements
- Scan up to 5 times faster than traditional methods
- Network compatible
- Prints hold and pass product labels
- Windows operating system
- Touch screen controlled
- User friendly screen layouts
- Stores all quality data in electronic format for easy retrieval
- One-step belt removal for rapid sanitation
- Data can be uploaded into current SPC program



QC Simple™

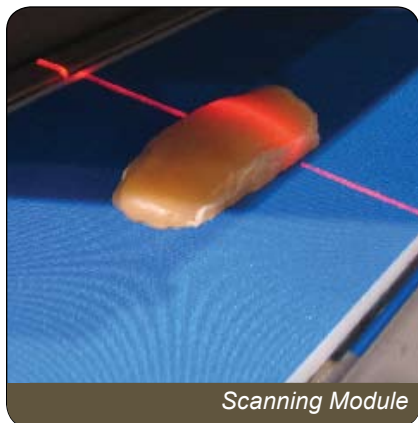

Scanning Module

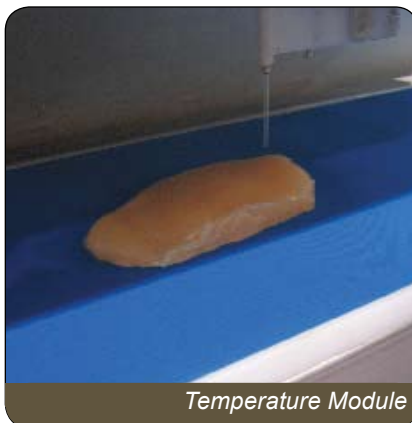

Temperature Module

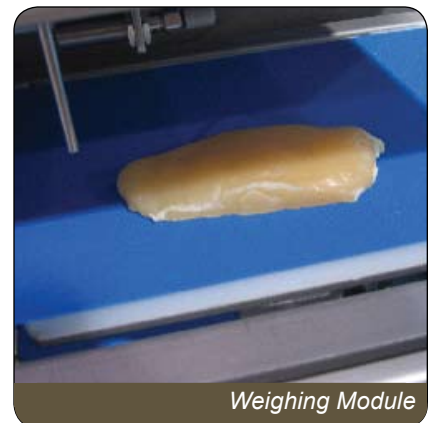

Weighing Module

QC Simple™

Technical Information

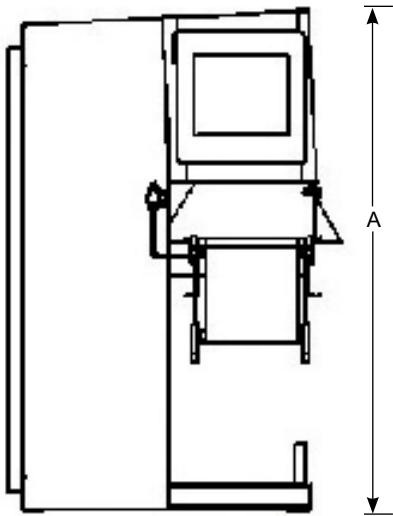

End View

MACHINE DIMENSIONS

Machine	A	B	C
QC Simple™	73"	38"	61"

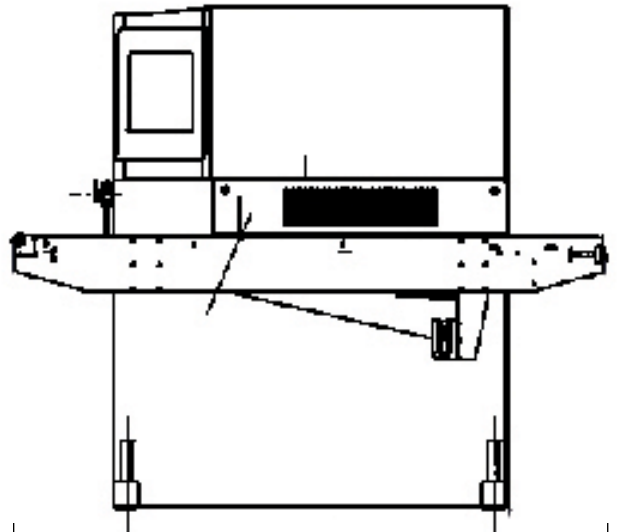

Side View

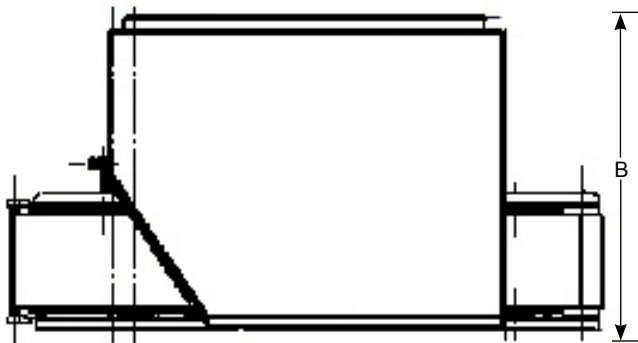

Top View

- SERVICES OFFERED -

- 24/7 Service
- Spare Parts Department
- Application Support
- Technical Support
- Line Audits

- MP WARRANTY POLICY -

MP Equipment will repair or replace any MP manufactured component that fails due to defect in material or workmanship within 24 months from shipment.

All OEM parts covered by individual warranties.

Specifications subject to change

UTILITY MATRIX

Voltage	120 VAC
Max Amps	20 Amps
Water	1 GPM

Standard configuration:

Dimensional scanning module, temperature module and weighing module

MP EQUIPMENT COMPANY
Your Best Value for Processing Solutions