

NEW!



MPADVANTAGE™ MegaJet™ Water Cutter

THE MEGAJET™ FEATURES THE HIGHEST CAPACITY, MOST ACCURATE, RELIABLE AND FLEXIBLE WATER JET TECHNOLOGY IN THE INDUSTRY

The groundbreaking technology in this machine creates the highest-yielding water cutter in the industry

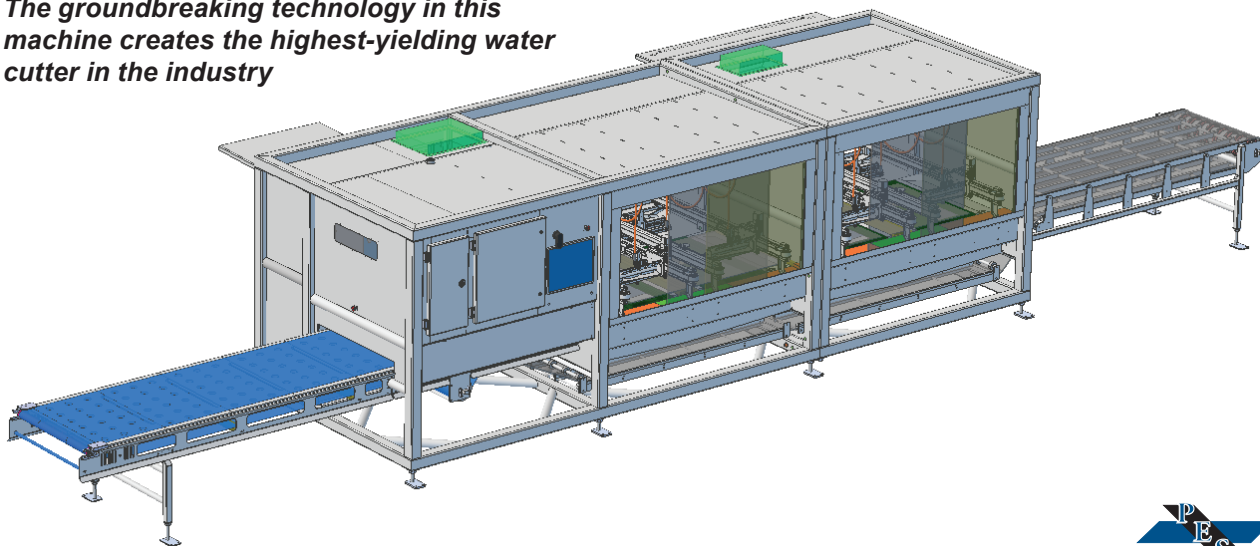

MPADVANTAGE™ MegaJet™

Engineered and manufactured by PES, Inc., and offered exclusively by MP Equipment Company. Size protein products with the most user-friendly operations available, while drastically improving yields and throughputs over all current options.



Strips, Nuggets, Fillets, Fat Trimming and More

MegaJet™ Benefits:

- Highest capacity water cutter on the market
- 8 XY Cutters across 2 lanes of production, with customizable configurations available to fit your specific needs
- Fully integrated stainless steel high pressure pump
- State of the art camera system
- User friendly Windows operating system
- Dual touch screen controls with user friendly operator interface
- 5 year non-obsolescence guarantee
- Complimentary software upgrades
- Flexible quick disconnect high pressure hoses
- Quick and inexpensive installation
- Online trouble shooting support
- Maintenance and production charting and trending

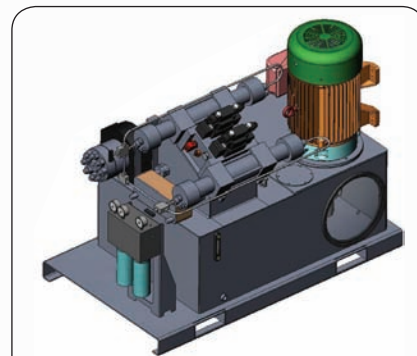

Fully-integrated pump

MPADVANTAGE™ MegaJet™

Technical Information

Some of the many other possible MegaJet™ cut applications



Nuggets | Butterfly w/Nuggets | Strips | 4-Way | Fillet w/Nuggets | Choice Cut | Optical Fat Trimming (OFT)

MACHINE DIMENSIONS

| Machine | A | B | C |
|----------|------|-----|-----|
| MegaJet™ | 472" | 84" | 80" |

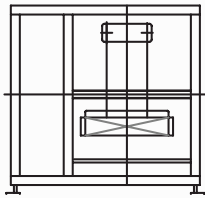

INFEEED END

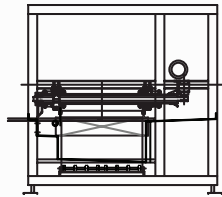

OUTFEED END

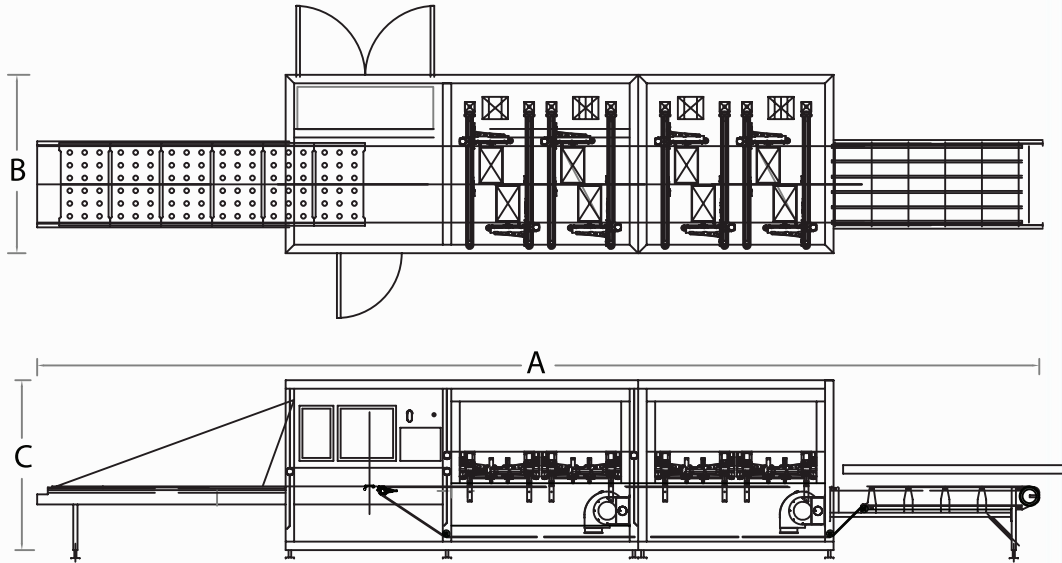

MACHINE SPECIFICATIONS

| | |
|----------------------|----------------|
| Infeed Length | 117" |
| Outfeed Length | 109" |
| Overall Length | 472" |
| Belt Width | 36" |
| Belt Speed | 10 – 80 ft/min |
| Number of XY Cutters | 8 |

UTILITIES

| | |
|------------------------|-----------------|
| Voltage | 480 VAC |
| Max Machine Amp Draw | 100 |
| Max Pump Amp Draw | 150 |
| Total Electrical | 250 Amp Breaker |
| Water Usage Cutting | 2 GPM |
| Water Usage Cooling | 4 GPM |
| Total Water Usage | 6 GPM |
| Minimum Water Pressure | 80 PSI |
| Air Requirement | 5 CFM @ 100 PSI |

Specifications subject to change

- SERVICES OFFERED -

- 24/7 Service
- Spare Parts Department
- Application Support
- Technical Support
- Line Audits

- MP WARRANTY POLICY -

MP Equipment will repair or replace any MP manufactured component that fails due to defect in material or workmanship within **24 months** from shipment.

All OEM parts covered by individual warranties.

MP EQUIPMENT COMPANY

Your Best Value for Processing Solutions

